

**Bench:**

**Class:**

**Shooter:**

**Relay:**

**Match:**

**X's:**

**Score:**



Batch:2013-09

50m Rimfire

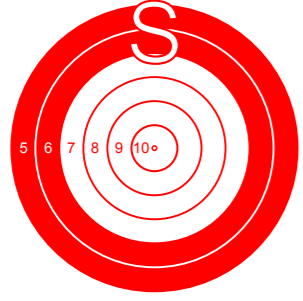
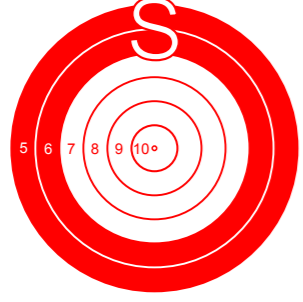
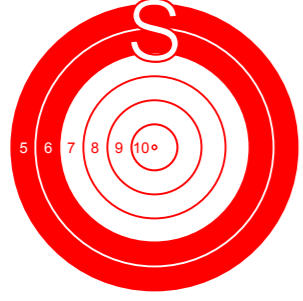
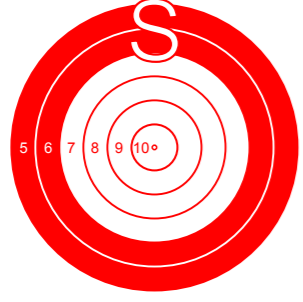
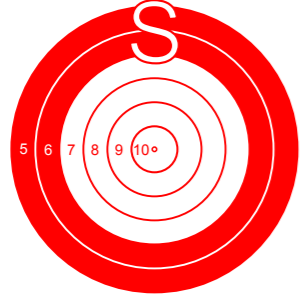

50m Rimfire

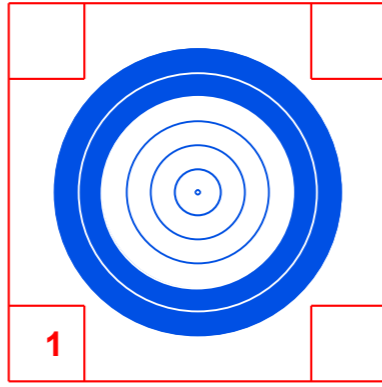

1

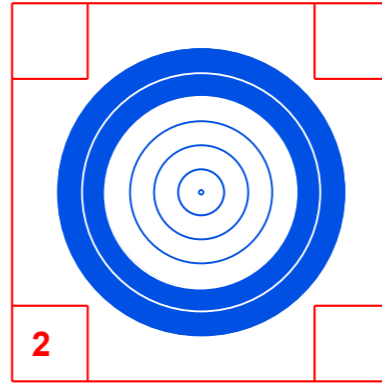

2

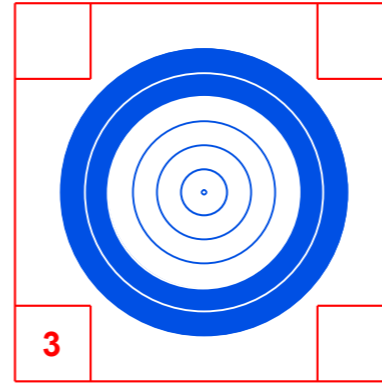

3

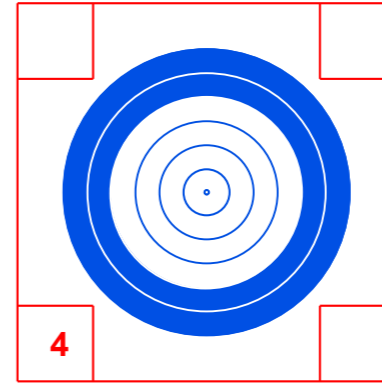

4

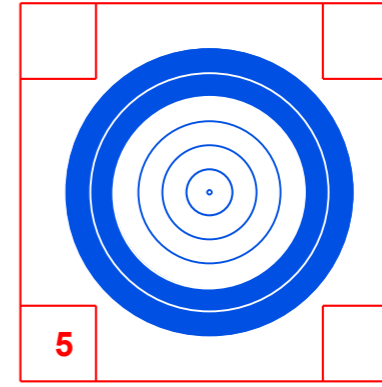

5

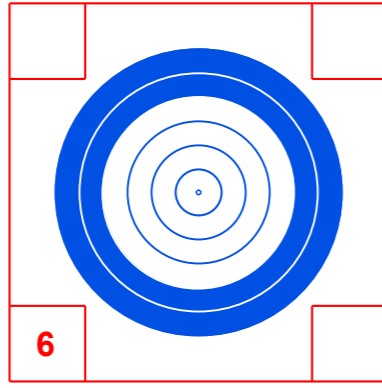

6

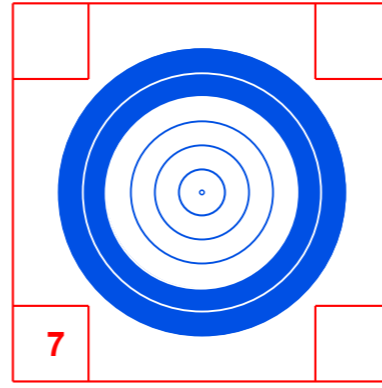

7

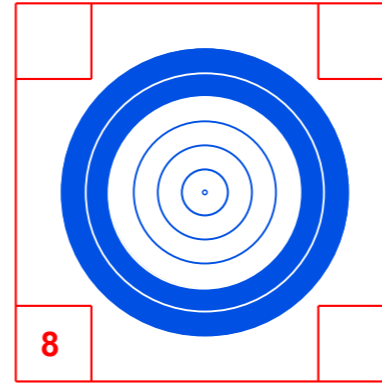

8

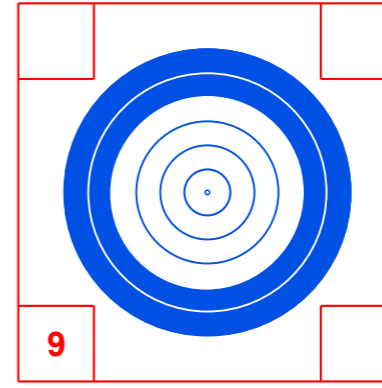

9

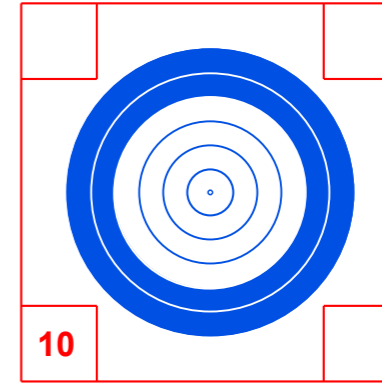

10

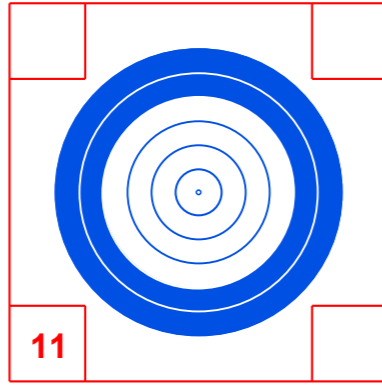

11

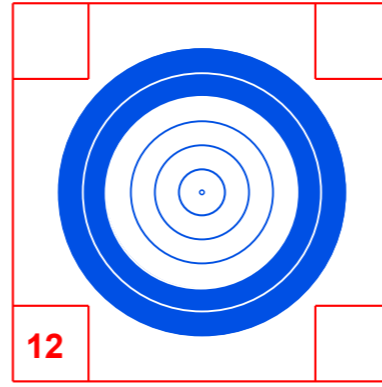

12

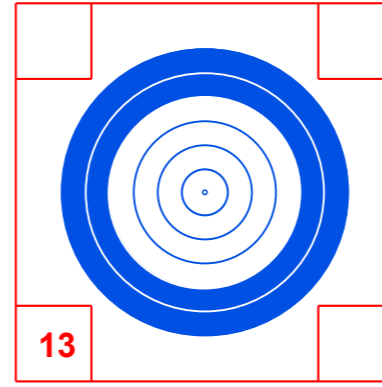

13

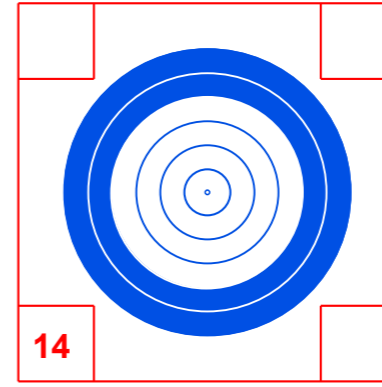

14

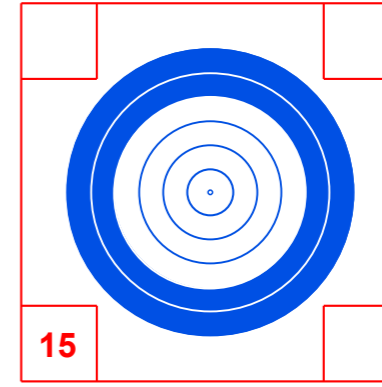

15

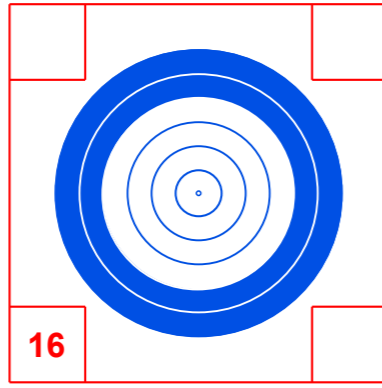

16

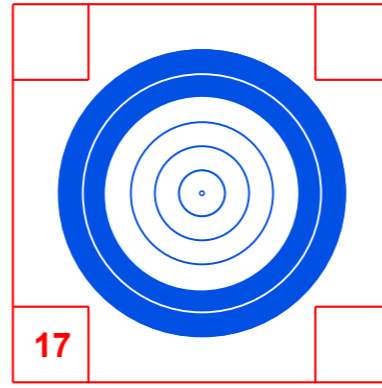

17

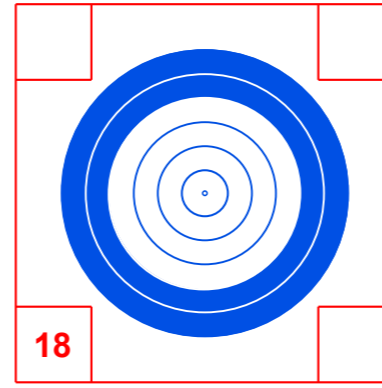

18

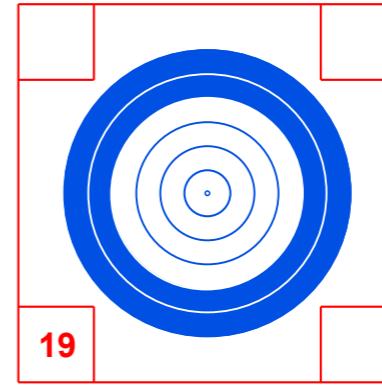

19

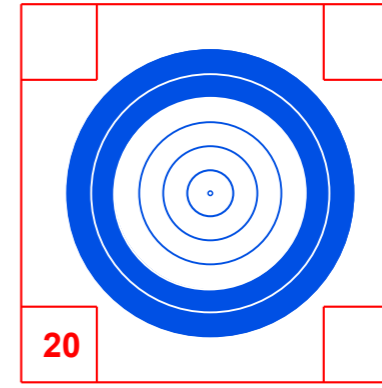

20

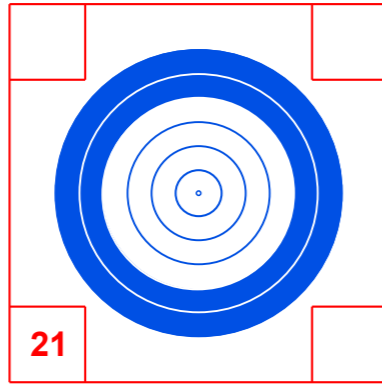

21

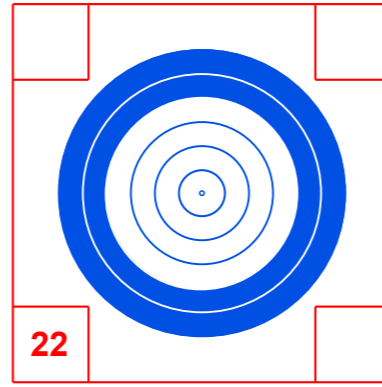

22

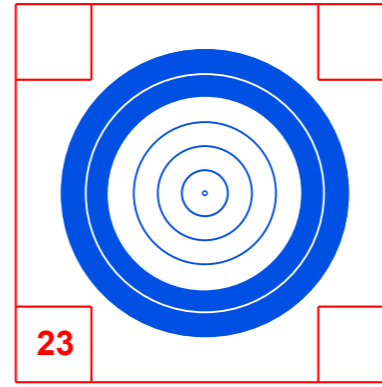

23

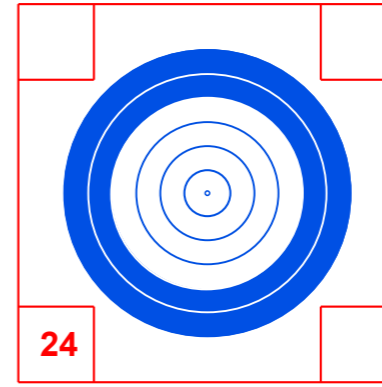

24

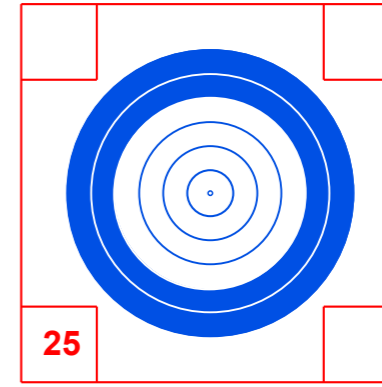

25

50m Rimfire

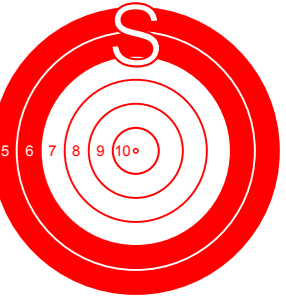
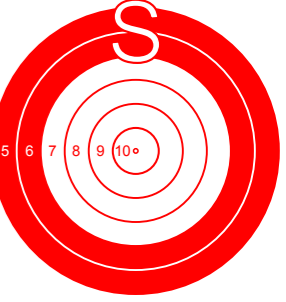
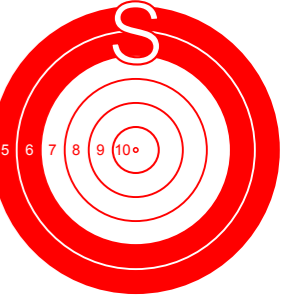
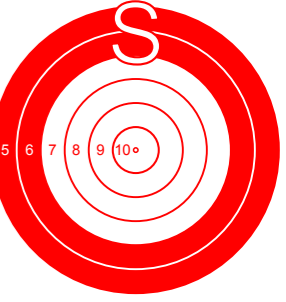
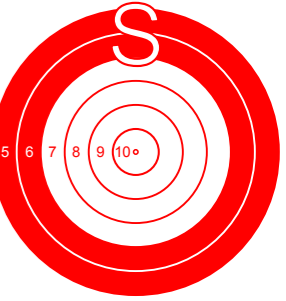

50m Rimfire